

PITCHMASTIC PmB

International

Solutions for
**Bridges,
Highways &
Infrastructure**

www.pitchmasticpmb.com

PITCHMASTIC PmB

1945	Established as Northern Roofing, Sheffield, UK
1960's	Acquired quarries in Derbyshire, UK & began to manufacture mastic Asphalt
1970's	FPA Pitchmastic BUR & mastic asphalt contracting established
1980's	Continued expansion to a nationwide manufacturer & contractor
1990's	Developed PmB waterproofing with Bayer
1990's	First material export to Middle East - Gantoot, Abu Dhabi, UAE
2000	Established International sales and regional offices throughout GCC
Today	11,000 bridge projects completed globally with 300 in the Middle East



158,000m² of PmB Waterproofing applied to Al Sowah Island, Dubai UAE.

Company Profile

Pitchmastic PmB International is a specialist manufacturer supplier and installer of high performance waterproofing systems, expansion joints and combined kerb & bridge drainage on a global basis.

Pitchmastic PmB International has in-house knowledge, practical application and technical experience that spans over 70 years. Even from the early days Pitchmastic PmB International's research and development was key to its success in an embryonic, technically challenging and rapidly evolving construction marketplace.

Pitchmastic PmB International's global activities are dealt with from a number of offices around the world and managed through the company's Middle East office located in the UAE as well as regional branches in Qatar, Oman, Kuwait and Singapore. Pitchmastic PmB International has a dedicated management team, technicians, equipment and material warehousing to support all their client needs.

Backed by parent company RPM Inc, Pitchmastic PmB International continues to strive and develop opportunities around the world by providing clients with professional customer care, full technical, operational and product support.

Industry Leading Brands

"USL Group brings together under one umbrella some of the finest civil engineering and construction solutions available worldwide."



Pitchmastic PmB International has the capability of supplying and installing all products offering their clients the comfort of single source responsibility, whether it be undertaking complex expansion joint projects or large waterproofing schemes requiring multiple crews.



Pitchmastic PmB International's team liaise closely and offer technical support and site assistance to all commercial clients, consultants and main contractors - they stay involved through the whole project life cycle:

Delivering exceptional projects worldwide

- Step 1:** Technical support & consultancy
- Step 2:** Formulator & manufactured solutions
- Step 3:** Comprehensive quotation - specialist sub-contractor
- Step 4:** Expert local knowledge & labour resource
- Step 5:** Supply & install solution provider
- Step 6:** Quality control & guarantee
- Step 7:** Project completion & financial closure
- Step 8:** Repeat business & recommendations

International Test Accreditation

- Department of Transport BD47/99, BBA HAPAS UK
- LSETR Cert RAT 9359 Finland
- BAM Institute ZTV-BEL B3/87 Germany
- LTA Singapore
- EMPA Cert 4944-1-2-3 Switzerland
- THSR Specification 07140 Taiwan
- New Jersey Rail, New York DOT
- Various approvals GCC wide

International Approvals

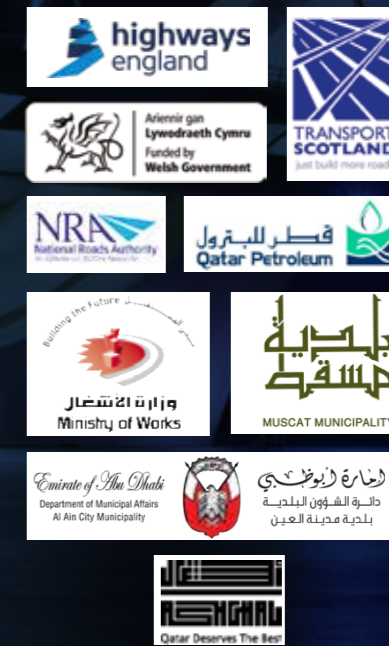

Bridges are at constant attack and under stress as water, chlorides, acid rain, de-icing salts and freeze thaw cycles act on them. Extreme weather cycles, the impact of traffic and vibration place bridges under further stress. As steel reinforcing bars corrode and expand, concrete can crack and deteriorate. The costly disruption caused by resulting repair work impacts on both traffic and safety.

Bridge repairs can often amount to 10-30% of the updated construction cost, and large repairs may even exceed the updated construction cost and still be the preferred option when compared to the cost of traffic interruption and demolition.

As moisture is the most significant factor in concrete deterioration, incorporating sufficient waterproofing at the design stage is by far the most cost-effective option.



Injection Resins
Page 36 - 38

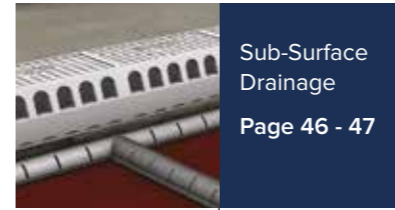

Sub-Surface Drainage
Page 46 - 47



Expansion Joints
Page 08 - 23

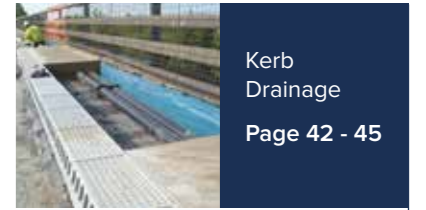

Kerb Drainage
Page 42 - 45

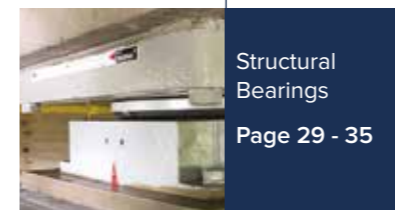
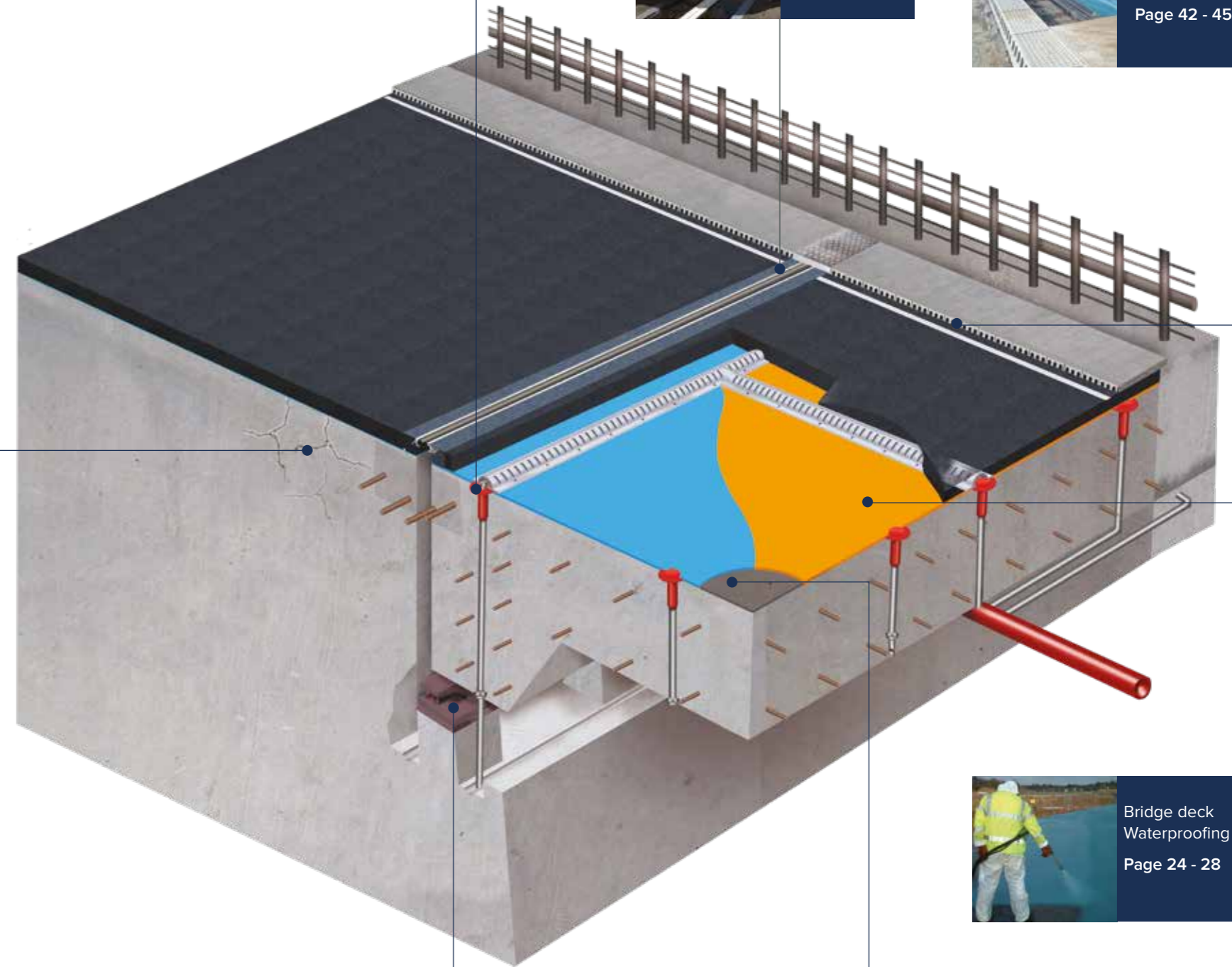

Structural Bearings
Page 29 - 35



Concrete Repairs
Page 39 - 41

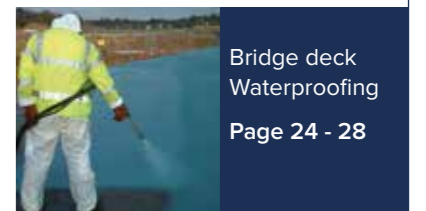

Bridge deck Waterproofing
Page 24 - 28

Expansion Joints

USL BridgeCare

EKSPAN

Expansion joint selection guide

Pitchmastic PmB International are market leaders in the manufacture, supply and installation of expansion joints which have been carefully developed to provide safe, efficient and economical methods of sealing construction gaps.

The bridge expansion joint range of products caters for movements up to 2000mm.

- Rapid on site assembly
- Minimal disruption to traffic
- Perfectly suited for lane by lane installation
- Minimised future maintenance costs
- Easy to install and detail at design stage
- Adaptable to numerous applications
- Excellent global track record
- Unparalleled bond to concrete and steel decks.

	Movement up to (mm)	Page No.
Uniflex (Type 1)	20mm	09
BP1 (Type 1)	20mm	10
Feba (Type 2)	40mm	11
Britflex NJ (Type 4)	40mm	12
Transflex (Type 5)	330 mm	13
Transflex HM (Type 5)	1600mm	14 & 15
Britflex BEJ (Type 6)	150mm	16
MEJS (Type 6)	2000mm	17
Finger/Comb (Type 7)	1000mm	18
LJ (Longitudinal Joint)	220mm	19
T-Mat	260mm	20
Roller Shutter ES	800mm	21
Open Type (Rail Joint)	260mm	22
UCP (Pedestrian Joint)	70mm	23

Uniflex Type 1 Buried Joint Under Continuous Surfacing

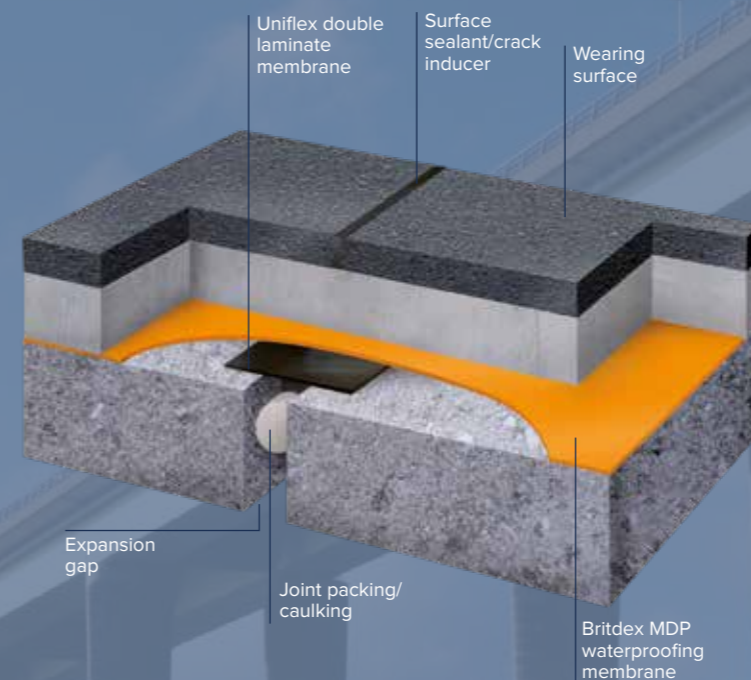

This system uses a butyl rubber membrane, bonded to the substrate with **Uniflex** epoxy Adhesive to provide an efficient and permanent expansion joint that is easily installed. The system will accommodate a variety of conditions from those experienced on an asphalt-covered traffic-free roof, to bridge decks with sheet membrane, spray on coating or asphalt waterproofing, also it can be used with two layer mastic asphalt or brick paving systems.

The **Uniflex** membrane is prepared from specially developed butyl rubber compound that is tough, weatherproof, flexible and can withstand up to 300% elongation. The **Uniflex** epoxy adhesive has been designed specifically for bonding **Uniflex** to concrete, asphalt and other surfaces to make the system effective. The **Uniflex** membrane is normally supplied in 20 metre rolls of any required width up to 1300mm, adhesive, closed cell foam and steel plates if required are all part of the different systems we can provide.

The **Uniflex** system is chemically inert and completely impervious to water and water vapour. In buried joints the membrane is completely protected by the wearing surface. **Uniflex** membrane will not rock or crack in service and the combination of a simple design and proven components makes the system naturally long-lasting and well up to the requirements of modern building and civil engineering practice.

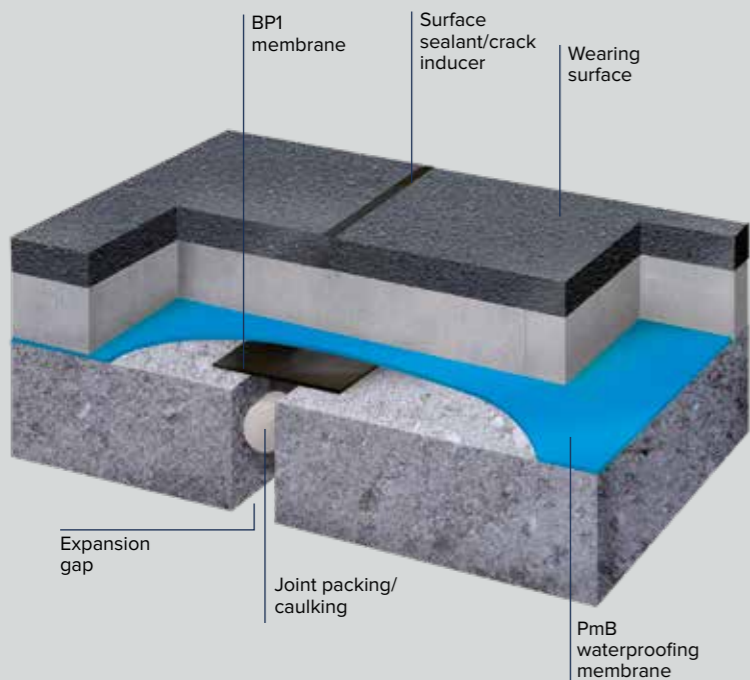

BP1 is a buried joint, incorporating polyethylene, which is placed into the air gap flush with the concrete surface. The deck is then primed using PMCS/01 and over the joint area. The whole area is then sprayed with PmB 2mm nominal thickness waterproofing layer.

Within 4 hours the 300mm overlay is sprayed on top of the existing 2mm waterproofing layer finally installing a saw cut to surface.

System Benefits:

- Movement Range $\pm 10\text{mm}$
- Highways England Approved Product

Applications:

- Bridges
- Roads

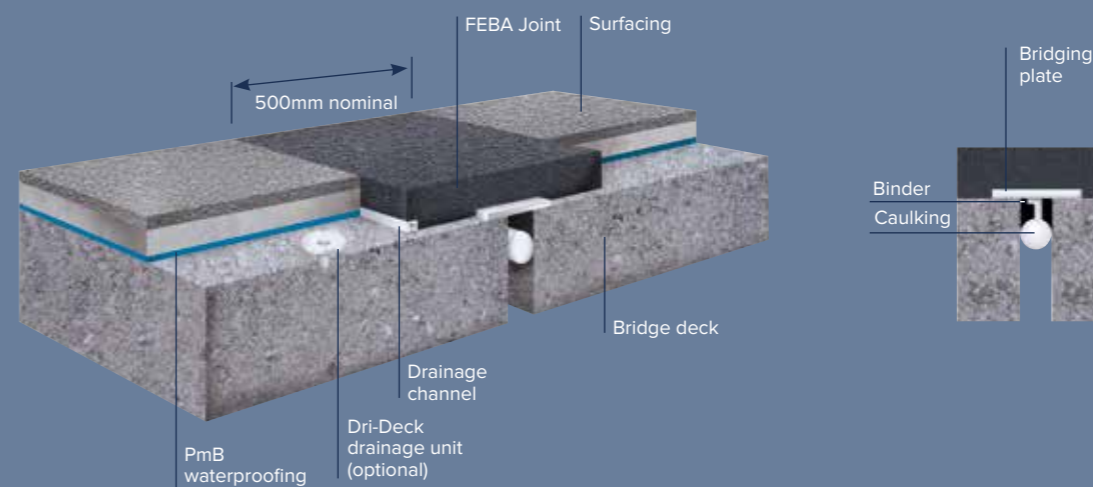
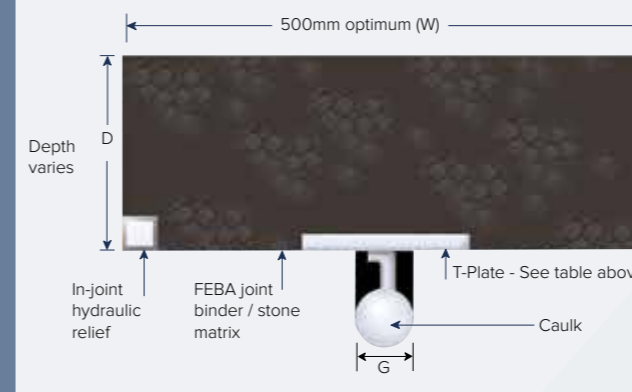

Table 1 - Joint gap (refer to G on section below)

Joint Gap (Max.) mm	T-Plate thickness mm
Up to 45	1.5
45 - 70	3
70 - 95	6



FEBA joint extends across the full length of the carriageway and into the verges.

Pitchmastic PmB International offers three grades of asphaltic plug joint systems, all in accordance with BD33/94 standard for use on all classes of highway bridges.

The binder is selected depending largely upon climatic conditions, bridge movement factors, cross-falls and the nature of traffic also are considered.

FEBAJOINT - is a standard asphaltic plug joint which provides a flexible, waterproof joint with excellent ride quality for users and noiseless characteristics for minimal impact on the environment. Asphaltic plug joints are recognised as being suitable for a maximum design movement of $\pm 20\text{mm}$ horizontally and $\pm 1.5\text{mm}$ vertically and are ideal for use on bridges with low traffic volumes such as B roads.

FEBA HM - is a high modulus asphaltic plug joint suitable for low to medium movement of $\pm 20\text{mm}$ on heavily trafficked highway bridges. **FEBA HM** is a special blend of bitumen, polymers, fillers and a surface active agent, formulated to combine good fluidity at process temperatures with low temperature flexibility and ambient temperature slump control. The use of basalt aggregates (BS EN 13043) ensures excellent load bearing capacity and high resistance to wheel tracking. This amalgamation of a highly interlocking aggregate allows the system to provide excellent anti rutting characteristics.

FEBA HC - A bituminous asphaltic plug joint which has been developed for use in hot climates. **NOTE:** Design, construction and installation criteria remain the same for all joint types.

Table 1 - Design detail

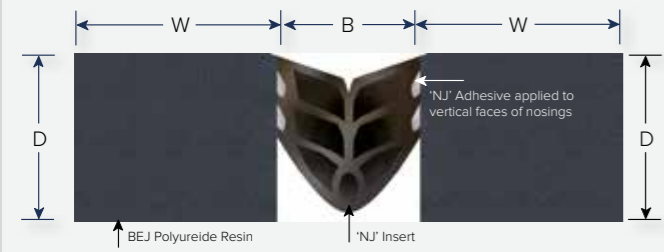

	Total Movement Capacity		Minimum Nosing Size		Optimum* Nosing Gap 'B'	Nosing* Gap 'B'	
	Horizontal	Vertical	W	D		Min	Max
NJ 1	15	±3	100	60	30	20	35
NJ 2	20	±5	100	60	30	20	40
NJ 4	40	±10	100	60	50	30	70

All dimensions in mm

Notes

The 'W' and 'D' dimensions are the minimum for new works contracts. For refurbishment contracts, nosing width and depth can be varied, however the 'W' and 'D' dimensions should always be based upon a minimum aspect ratio of 1.25:1, width to depth.

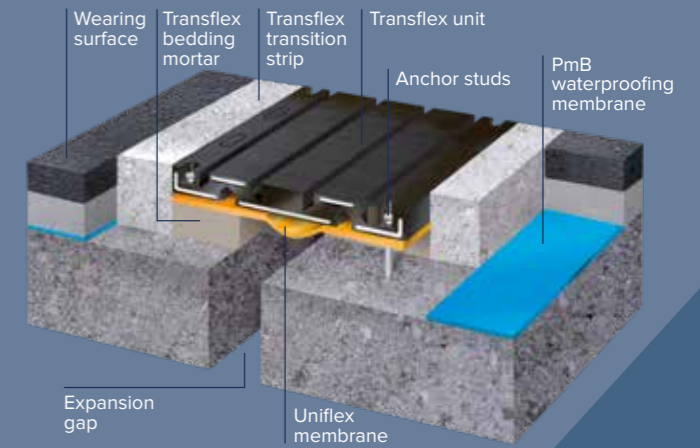
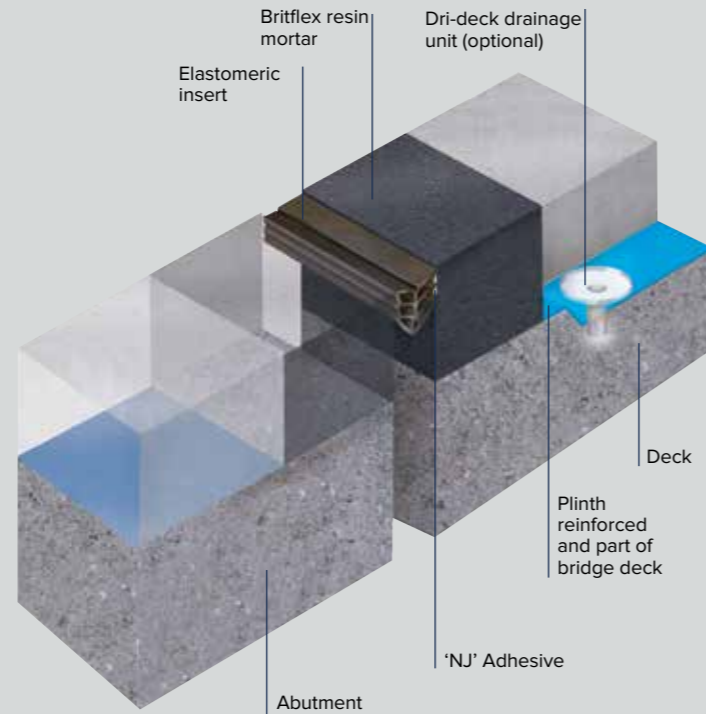

Pitchmastic PmB International Transflex bridge joint models

Models	Movement accommodation	Module length	Module width B	Module depth A	Stud diameter D	Module weight	Max joint width at mid-deck temp N	Max joint width O	Recess depth R	Transition strip width W
150	38mm	1750mm	240mm	35mm	12mm	30kg	35mm	54mm	41mm	100mm
200	50mm	1830mm	274mm	40mm	12mm	48kg	51mm	76mm	46mm	100mm
250	65mm	1830mm	356mm	46mm	16mm	68kg	67mm	98mm	52mm	100mm
300	76mm	1830mm	432mm	52mm	20mm	88kg	83mm	121mm	58mm	100mm
400	102mm	1830mm	590mm	54mm	20mm	150kg	102mm	152mm	60mm	100mm
650	165mm	1830mm	724mm	75mm	24mm	272kg	121mm	203mm	81mm	125mm
900	230mm	1830mm	890mm	93mm	24mm	375kg	158mm	273mm	99mm	150mm
1300	330mm	1220mm	1204mm	127mm	30mm	451kg	216mm	381mm	133mm	175mm

Note: Add 3mm to the recess depth 'R' when using the Uniflex secondary membrane.

A surface mounted nosing joint with an elastomeric insert bonded to the rapid curing elastomeric compound known as Britflex® Resin Mortar.

In the UK the Britflex® NJ system can only be used in the situation where the gap at carriageway level does not exceed 65mm for gaps above 65mm the 'BEJ' system would be used.

The Britflex® NJ joint is an ideal system for maintenance situations and has been developed to provide a whole life economic solution for applications where asphalt plug joints are unsuitable.

Advantages

- Versatile
- Substantially waterproof
- Rapid installation
- No drilling of deck
- No mechanical fixings
- Quiet comfortable riding characteristics



The Transflex expansion joint system is registered with Highways England, for use on highway bridge decks on all classes of roads and motorways. (BD 33/94: Joint Type 5 refers).

Britflex Resin Mortar is included in SA1 as an approved material for transition strips to all types of expansion joint. Transflex bridge joints comprise of steel angles and a steel bridging plate system encased in a flexible elastomer.

They are supplied in module lengths designed to be bolted to the structural concrete on either side of the expansion gap. A range of models are available to accommodate movement up to 330mm, providing a substantially waterproof joint and a smooth running surface.

Advantages

- Movement accommodation up to 330mm
- Corrosive resistant elastomer casing
- Accommodates skew movement
- Factory vulcanised kerb and skew kerb units to special order
- Membrane system included for maximum waterproofing

Applications

- Highway bridge decks
- Service Ramps
- Multi-storey car parks

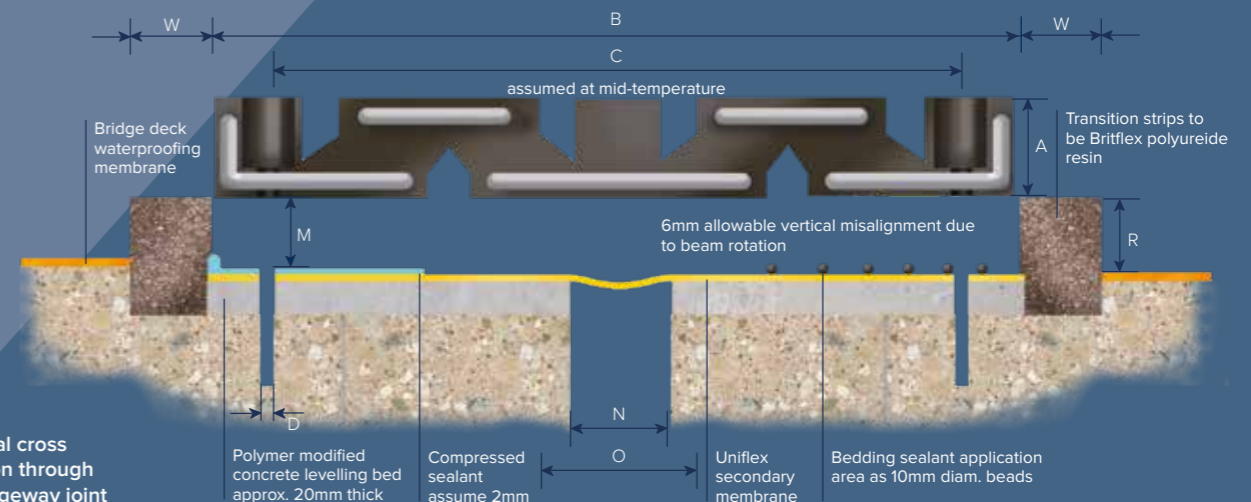

Typical cross section through carriageway joint

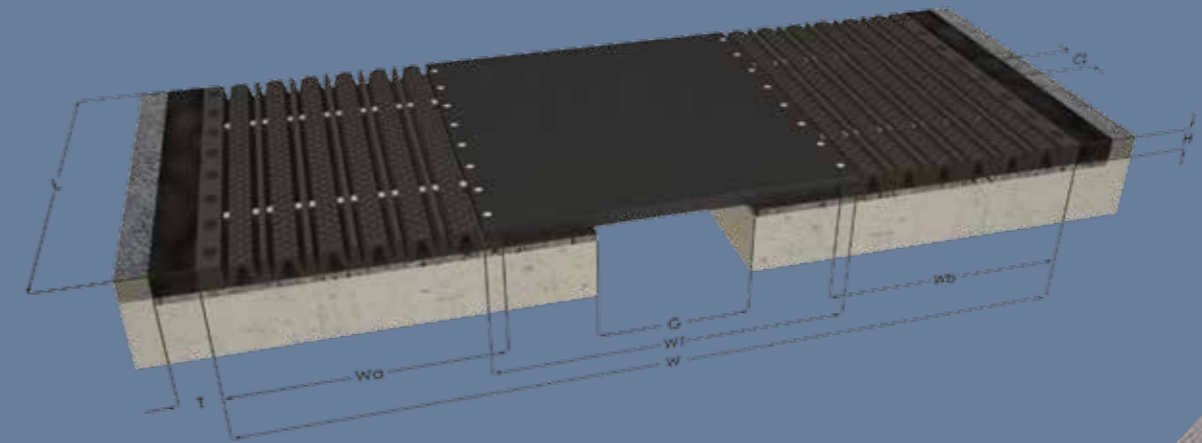
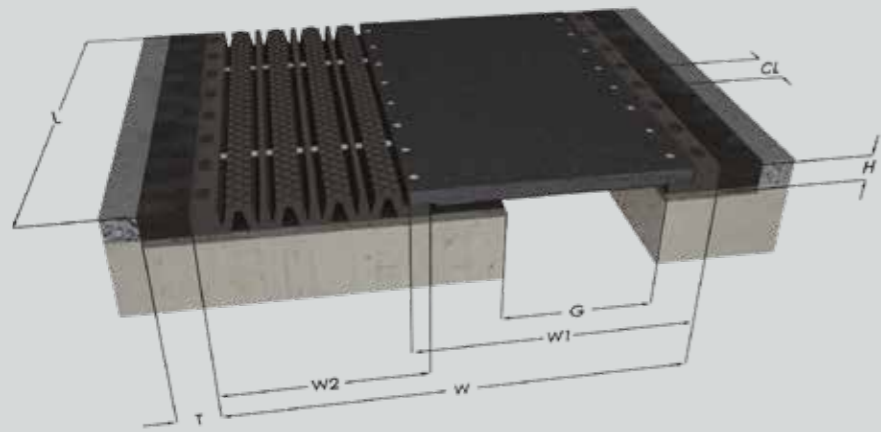

The High Movement **Transflex** expansion joints have been designed to cover large movements. They consist of up to three modules, two movement modules and the bridging module. The movement modules are the “mobile” section of the joint, made of rubber and steel, to accommodate the expected movements. The bridging module is the “fixed” section of the joint, to bridge the structural opening.

The High Movement **Transflex** expansion joints absorb large movements while providing remarkable comfort to traffic, effective sealing, low maintenance and easy replacement.

High Movement **Transflex** models cover a movement range from 400mm to 1600mm.

Advantages

- Corrosion resistant elastomer casing
- Movement accommodation up to 1600mm
- Seismic movement capability
- Accommodates skew movement
- Factory vulcanised kerb units to suit changes in levels
- Easy replacement

Models	Movement (mm)	L (mm)	H (mm)	W (mm)	W1 (mm)	W2 (mm)	Wgt (kg)	CL (mm)	G (mm)	T (mm)
1600	400 (±200)	1600	85	1280	675	675	460	200	220	170
2000	500 (±250)	1600	85	1520	775	815	585	200	270	170
2400	600 (±300)	1600	85	1760	875	955	710	200	320	170
2800	700 (±350)	1600	85	2000	975	1095	765	200	370	170
3200	800 (±400)	1600	85	2240	1075	1235	930	200	420	170

Models	Movement (mm)	L (mm)	H (mm)	W (mm)	W1 (mm)	W2 (mm)	Wgt (kg)	CL (mm)	G (mm)	T (mm)
3600	900 (±450)	1600	85	2440	1090	675 815	1050	200	470	170
4000	1000 (±500)	1600	85	2680	1190	815 815	1250	200	520	170
4400	1100 (±550)	1600	85	2920	1290	815 955	1440	200	570	170
4800	1200 (±600)	1600	85	3160	1390	955 955	1630	200	620	170
5200	1300 (±650)	1600	85	3400	1490	995 1095	1850	200	670	170
5600	1400 (±700)	1600	85	3640	1590	1095 1095	1980	200	720	170
6000	1500 (±750)	1600	85	3880	1690	1095 1235	2165	200	770	170
6400	1600 (±800)	1600	85	4120	1790	1235 1235	2350	200	820	170

Table 1 - Design detail

BEJ	Movement ⁴ Capacity		Minimum Nosing Sizes		Nominal ¹ Nosing Gap	Minimum Nosing Gap	Maximum Nosing Gap	Cover to ² Services	Kerb Upstand ³ Clearance	Optional Kerb ³ Detail
	Horizontal	Vertical	C	D	B	B.Min	B.Max	E	X	W
3	35	±12	100	60	45	25	60	70	125+125 tan a	225
5	50	±15	120	60	55	30	80	70	125+135 tan a	270
8	80	±15	140	70	70	30	110	85	125+145 tan a	310
10	100	±15	160	70	90	40	140	105	125+160 tan a	365
13	130	±15	180	70	115	45	175	165	125+170 tan a	405
15	150	±20	200	70	125	50	200	180	125+180 tan a	445

Note: Elastomeric insert changes according to joint size

All dimensions in mm

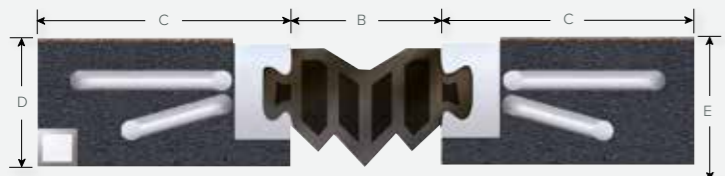

Notes

- Nominal nosing gap is that selected at average design effective bridge deck temperatures and does not take movement into account other than temperature movements.
- This is the standard design. Please refer to USL Technical and Advisory Service if a 'special' is required.
- For optional kerb detail based on minimum nosing widths – refer to the technical brochure.
- For skew movements, greater than ±15mm, please refer to Pitchmastic PmB International Technical and Advisory Service.
- For clarification of kerb upstand clearance (x) refer to the technical brochure.

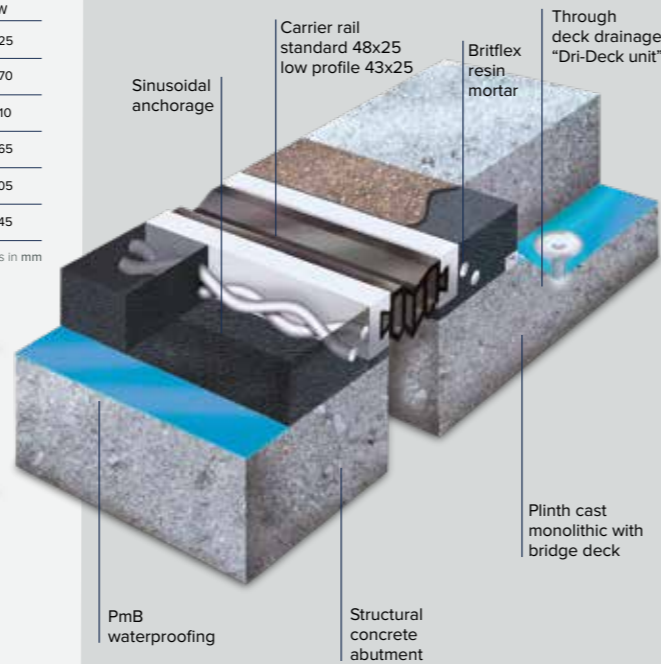
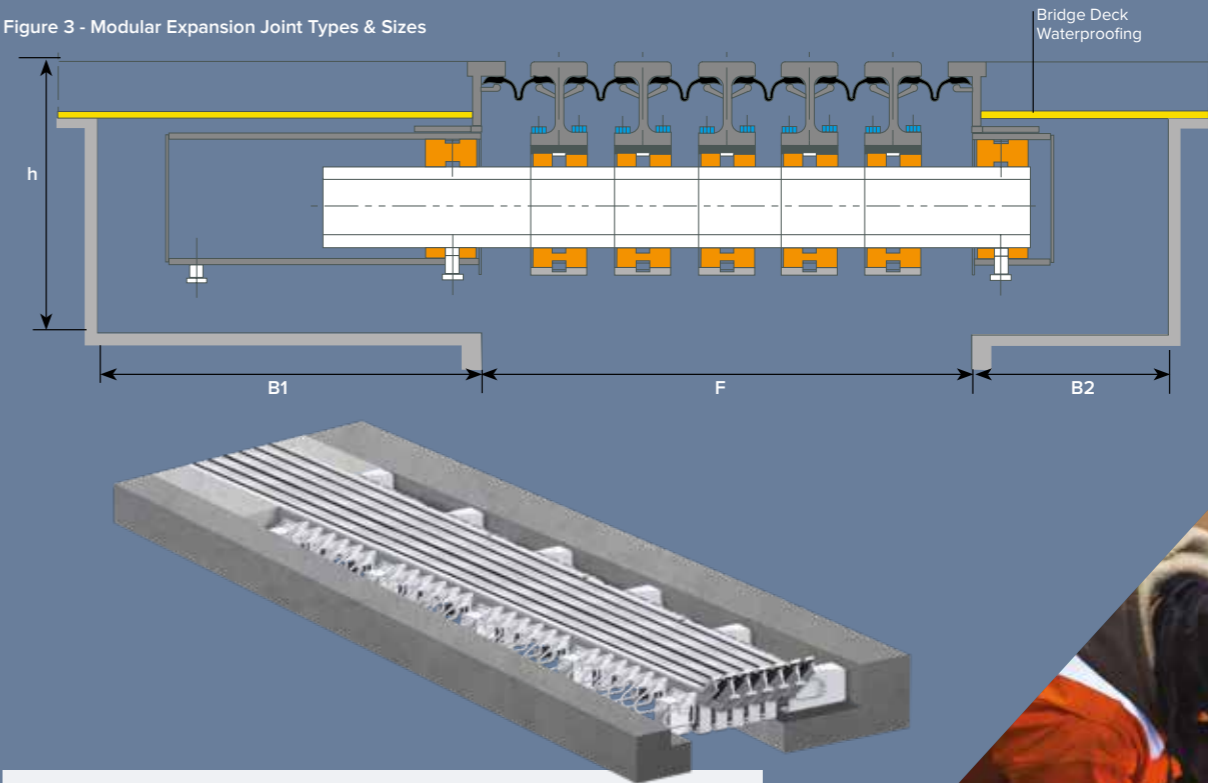

Figure 3 - Modular Expansion Joint Types & Sizes



Type	B1 (mm)	B2 (mm)	H (mm)	F(min) (mm)	F60 (mm)	F70 (mm)	F80 (mm)	G(WT) (kg/m)
LG2	400	400	400	140	260	280	300	150
LG3	480	300	400	220	400	430	460	210
LG4	560	300	400	300	540	580	620	250
LG5	640	300	400	380	680	730	780	290
LG6	720	300	400	460	820	880	940	410
LG7	800	300	420	540	960	1030	1100	500
LG8	880	300	440	620	1100	1180	1260	596
LG9	960	300	450	700	1240	1330	1420	745
LG10	1040	300	460	780	1380	1480	1580	1060
LG12	1200	300	500	940	1660	1780	1900	1340



A surface mounted mechanical system, with an elastomeric insert between two metal runners /carrier rails. Set into a, rapid curing resin compound known as Britflex® Resin Mortar. The polyureide resin provides unrivalled anchorage to the deck due to its remarkable bonding qualities, meaning that no mechanical fixings are required.

'BEJ' expansion joints incorporate cellular elastomeric inserts which are load bearing enabling a range of movement to be accommodated up to 150mm.

The Britflex® BEJ Expansion Joint system has worldwide approvals for use on bridge decks on all classes of roads and motorways. The Britflex® Resin Mortar, is also an approved material for transition strips to all types of expansion joints.

This system is ideal for maintenance projects where there is a need to replace ailing or failed systems. The major benefit this system will bring to any project is the speed in which it can be assembled on-site allowing phased work outside of peak traffic hours.

Advantages

- Rapid on site assembly
- Minimal disruption to traffic
- Minimised future maintenance costs
- Adaptable to numerous applications
- Britflex® Mortar provides excellent bonding versatility, offering equally strong bonds to both concrete and steel bridge decks allowing phased work outside of peak traffic hours.



A close up of the BEJ expansion joint system not normally seen by the travelling public.

MEJS is a mechanical device installed in bridge expansion joint openings. The primary function of the MEJS is to allow vehicle traffic to travel smoothly across large expansion joint openings. It does this by dividing the large expansion joint openings into a series of smaller openings called cells. These cells work together to accommodate the necessary thermal bridge movement (expansion and contraction) while providing a smooth riding surface for bridge vehicle traffic. The MEJS is normally used for expansion joints with a movement range up to 2000mm.

MEJS also has the secondary function of protecting the surrounding bridge superstructure and substructure. All MEJS cells are equipped with watertight sealing elements that prevent debris, water and corrosives such as de-icing chemicals from passing through bridge expansion openings and damaging superstructure and substructure components.

Advantages

- Durable
- Seal can be replaced without disturbing joint
- Low stiffness
- Allows vertical/skew movement
- Seismic movement capability

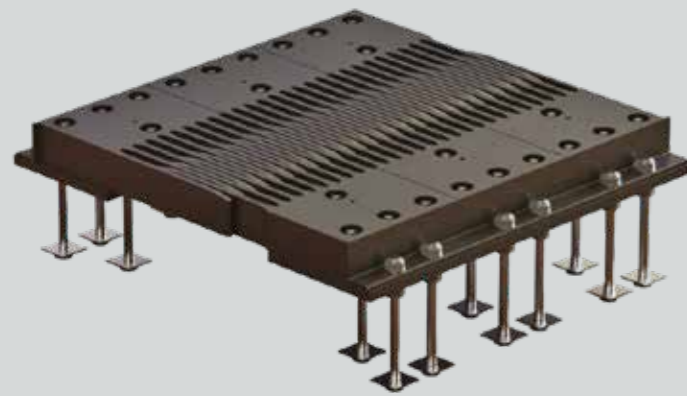

Finger type expansion joints are made up of fabricated or cast steel fingers and can be fitted mechanically as either continuous or modular sections in order to provide different options for clients needs.

They are very robust joints recommended for high performance requirements imposed by heavy traffic flows and movements on highways, accommodating both horizontal, vertical, and rotational movements.

Key Features:

- For movements up to 1000mm
- Long durability and good grip surfaces
- High performance and smooth riding comfort
- Lifespan of 40+ years

Applications:

- Motorways
- Road bridges
- Designed to suit applications - examples available

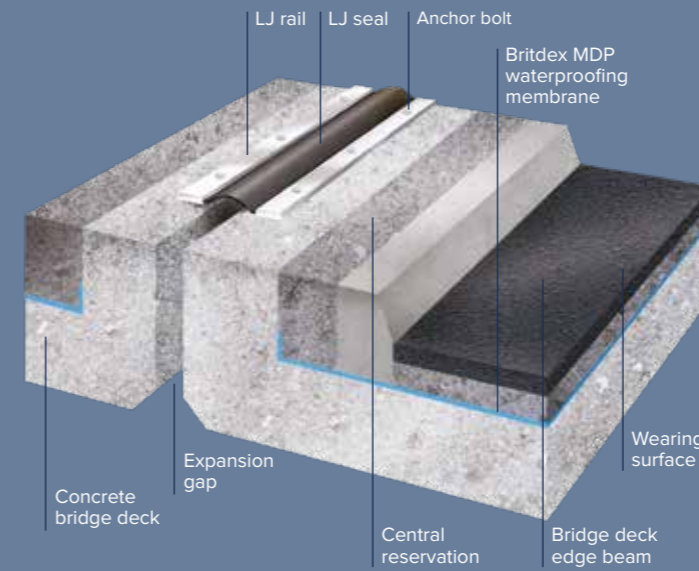

This system has been developed to provide an effective method of sealing longitudinal expansion gaps and soffits.

The joint can accommodate both longitudinal and vertical movement; the 'LJ' Joint also provides a substantially watertight seal to non-trafficked gaps between structures and is available in two sizes depending on the requirements of the individual project.

The 'LJ' Expansion Joint System has the flexibility to be used as a waterproof cover joint or alternatively as a drainage channel under joint with the facility to install drainage outlets into the system where required.

Advantages

- Rapid Installation
- Low maintenance
- Cost effective
- Installed by Pitchmastic PmB International's experienced and fully trained workforce.

Table 1 - Movement Capacity

LJ	Horizontal	Vertical
A	± 50mm	± 40mm
B	± 100mm	± 75mm





Type	Movement "X" Range	Movement "Y" Range	Movement "Z" Range	Hight (mm)	Width (mm)	Anchor Diameter (mm)
30	30mm (±15mm)	80mm (±40mm)	60mm (±30mm)	55	290	12
80	80mm (±40mm)	120mm (±60mm)	80mm (±40mm)	55	318	12
130	130mm (±65mm)	200mm (±100mm)	140mm (±70mm)	65	414	12
160	160mm (±80mm)	240mm (±120mm)	80mm (±40mm)	55	760	12
260	260mm (±130mm)	400mm (±200mm)	140mm (±70mm)	65	960	12

The **T-Mat** expansion joint consists of a solid armoured expansion mat made of a high quality chloroprene with metal reinforcements (T-bars).

The internal design of the expansion joint is such that due to the discontinuous steel reinforcement combined with the elasticity of the material (chloroprene), the expansion joint will not only allow for horizontal movement on either side of the joint but will also allow for transverse and vertical relative movements of adjacent bridge decks.

Structural safety during train and vehicle operation is guaranteed by the fact that the design of the expansion joint allows to carry and absorb the combined forces of load and traffic.

The expansion joint is designed to be installed in such a way that ballast can be put directly on top of the joint without any additional protection or treatment required.

The internal design allows also for high vertical movement due to differential settlement (up to ± 70 mm vertical and ± 100 mm transversal) without losing any of its other functional properties.

Key Features:

- For longitudinal movements from ± 15 (T30) up to ± 130 (T260)
- Impervious to deep standing water
- Low noise - ideal near residential properties

Applications:

- Motorways
- Rail & road bridges
- Primary/secondary roads
- Pedestrian walkways



Roller shutter joints are manufactured for dynamic structures with large longitudinal movements. They are designed to take high vehicle volumes/loads whilst providing a long operation service life.

Bridges using this type of joint for example are:

Forth Road Bridge, Severn Bridge, Humber Bridge, Avonmouth Viaduct.

Key Features:

- For movements greater than 800mm
- Durable and shown to resist seismic events
- High lifespan of the structure with low maintenance

Applications:

- Motorways
- Road bridges with large movements





These joints are specifically used for railway bridges for movements greater than 260mm.

They should be positioned in the vicinity of the expansion devices for continuously welded rails.

Applications:

- Rail Bridges

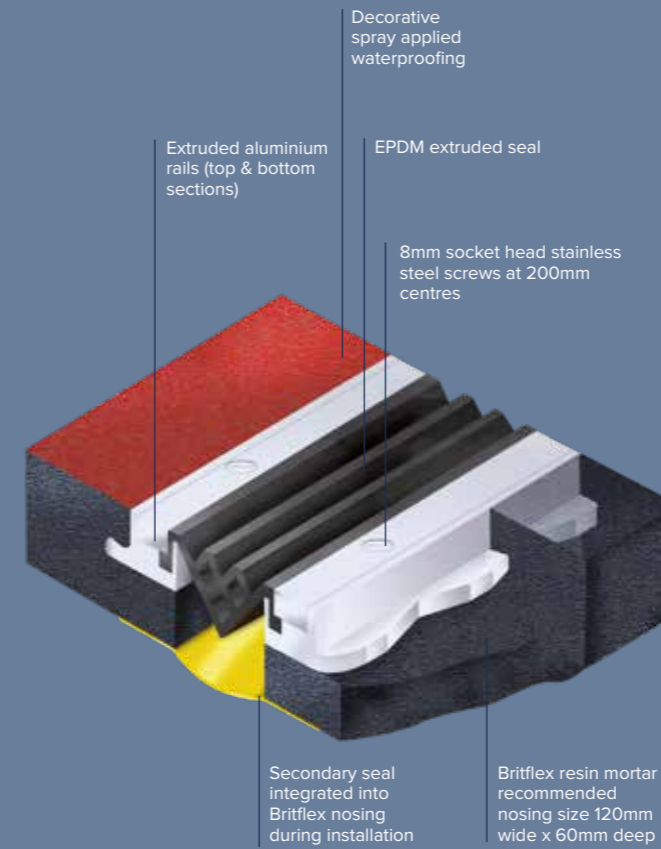

The system utilises the proven design of the 'BEJ' system, which have been extensively used throughout Britain's motorway network and the advantages of the 'BEJ system' have been adapted for use on footbridges and heavily pedestrianised structures.

There are two 'UCP' expansion joints; 'UCP' 50 and 70, capable of accommodating up to 50mm and 70mm of movement respectively. The system consists of heavy gauge aluminium rails, a resilient waterproof EPDM seal and an additional secondary waterproof membrane. This joint is totally sealed and will provide an impermeable seal to most liquids, salt and other abrasives, thus preventing premature damage to the structure.

There is a vast range of applications for this type of expansion joint, including:

- Multi Storey Car Parks
- Pedestrian Footbridges
- Podiums

Advantages

- Versatile
- Substantially waterproof
- Rapid installation
- No drilling of deck required
- No mechanical fixings
- EPDM Seal easily removed if required
- Provides quiet comfortable riding characteristics

UCP design detail

UCP	Movement Capacity		Minimum Nosing Sizes		Nominal Nosing Gap	Minimum Nosing Gap	Maximum Nosing Gap
	Horizontal	Vertical	C	D	B	B.Min	B.Max
50	50	±12	120	60	50	25	75
70	70	±15	120	60	70	30	105

All dimensions in mm

Movement capability up to 70mm

Bridge Deck Waterproofing



PmB	Page 25
Britdex MDP	26
CPM Tredseal	27
Uradeck	28

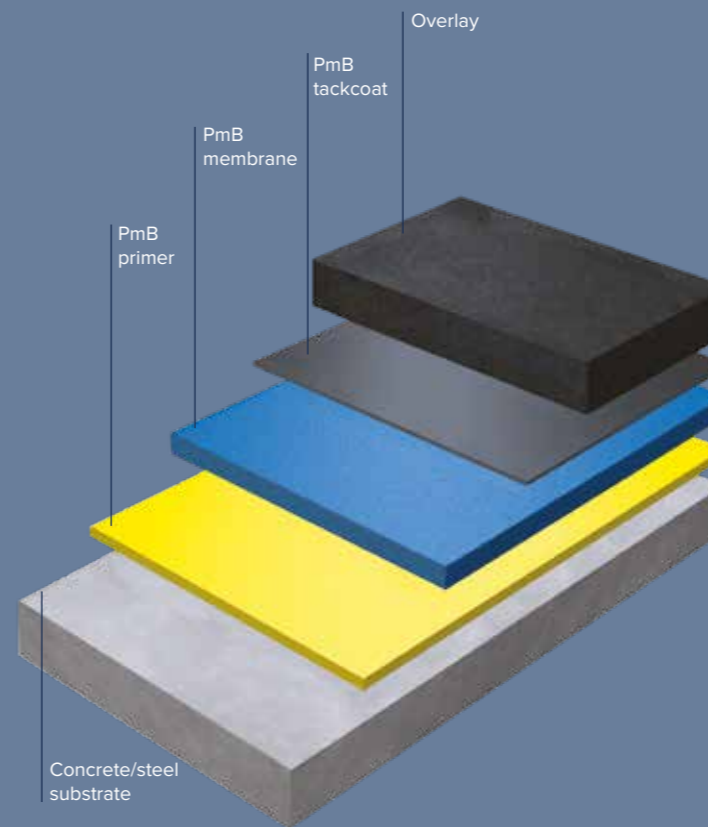

PmB is a two part, spray applied, durable corrosion protection and waterproofing material. The high performance system is 100% polyurethane containing no fillers or additives and is VOC free. Once applied, **Pitchmastic PmB** has exceptional bond strength to all commonly used substrates, has excellent crack bridging capability and a life expectancy in excess of 30 years and holds British Board of Agrément approval.

The system has gained BBA approval for use as a damp proof and waterproofing membrane for internal and external tanking. The system holds approvals in many continents including Europe, North America, the Middle and Far East.

Fast and Easy Installation

Pitchmastic PmB membrane is fast and easy to install and is applied as a single coat or in multiple layers. The two component materials of the membrane system are mixed at the spray gun and applied to the substrate using compressed air.

The spray equipment allows complete mobility, spraying vertical surfaces, overhead, behind pipe bays or over corners and edges quickly and effectively. This is achieved due to the membranes ability to gel in seconds preventing curtaining and providing instant protection.

Advantages

- Two component PUR spray system
- 100% solids reactive resin content
- Solvent free
- No fillers
- Rapid setting - 5-8 seconds gel time
- Tack free after approximately 1 minute
- Can be walked on after approximately 10 minutes
- Elastic after approximately 45 minutes

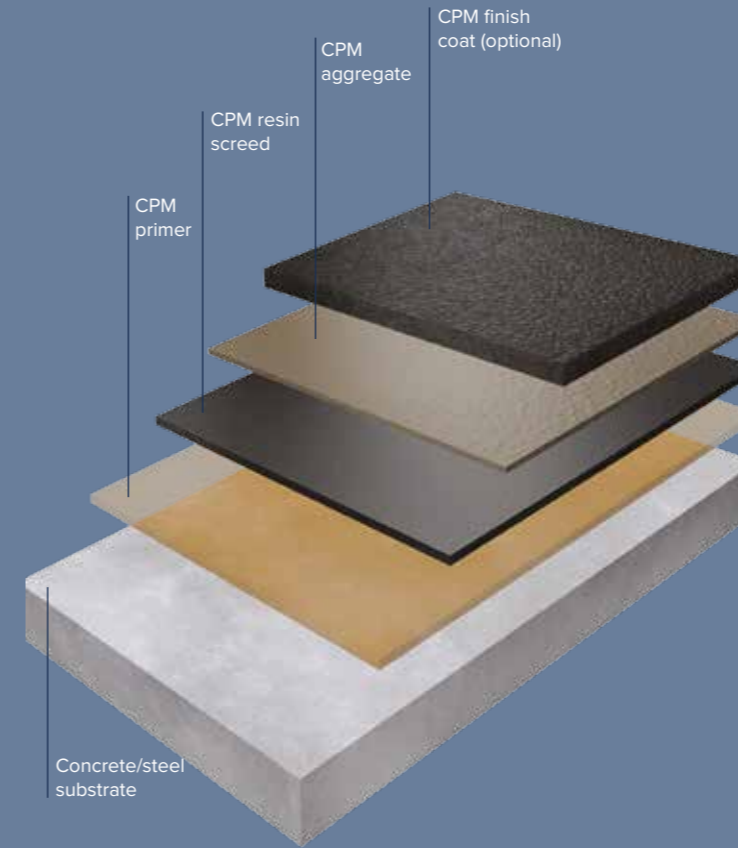
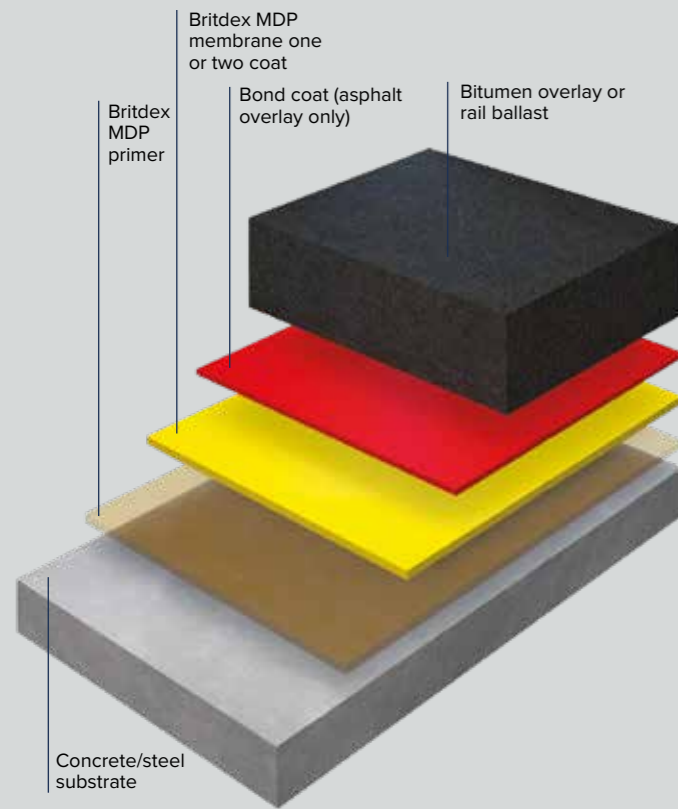

A Methyl Methacrylate (MMA) waterproofing system comprises of up to three separate environmentally friendly layers each offering different properties to the system. The system offers a 100% effective seamless bridge deck waterproofing membrane and the design of the system means that it is extremely durable and flexible, resulting in its suitability for application to a variety of surfaces and structures.

The rapid curing properties of each element of the **Britdex MDP** system means that substantial areas can be covered in short periods of time making the system extremely cost effective.

Due to the high durability of the system, it is unaffected by surfacing operations whilst offering excellent bond strengths to both the surfacing and the bridge deck.

Applications:

- Bridges
- Tunnels (Cut and Cover, Immersed Tube)

Advantages

- Seamless coating leaving no vulnerable joints
- Quick and easy application with rapid curing properties
- Excellent crack-bridging properties
- Environmentally friendly
- Durable effective protection against corrosion
- Versatile system - accommodates all surface contours, horizontal and vertical
- Application of the waterproof membrane can be one or two coats
- Highways England approved - BD47/99

Britdex CPM TredSeal is a combined waterproof wearing system, offering 100% effective waterproofing, wearing course and skid-resistance in a single surfacing layer, many times lighter than mastic asphalt.

Ease and speed of application to concrete, asphalt, steel or aluminium substrates results in minimal possession times and a faster return to service. **CPM TredSeal** can be used on a wide range of structures subject to differing traffic conditions, allowing them to be lighter by design.

Advantages

- Cost Effective
- Based on BBA approved technology
- Rapid set can be trafficked within two hours
- Easy and quick application
- Aesthetically pleasing finish
- Tough, flexible and hard wearing waterproof membrane
- Versatile surfacing, suitable for application on a number of different surfaces
- This system can be applied even at low temperatures
- Waterproof

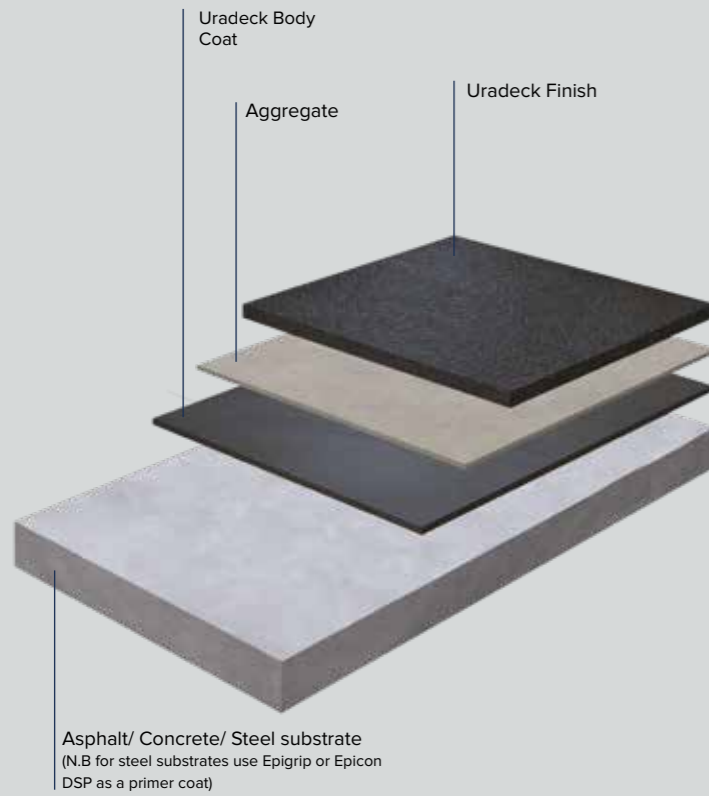

A two component polyurethane body coat characterised by its inbuilt flexibility, even at low temperatures. **Uradeck BC** provides excellent adhesion to a variety of substrates. By broadcasting slip resistant aggregate into the surface of the wet resin a highly durable anti-slip system can be produced.

The application of a decorative sealer coat is achieved with **Uradeck** finish.

System Benefits

- Excellent adhesion
- Inbuilt flexibility
- Good chemical and abrasion resistance
- Excellent weathering characteristics
- Fast setting for early trafficking
- Decorative finish
- Formulated to comply with the requirements of EN 1504 Part 2
- Manufactured in accordance with ISO 9001

Applications

- Waterproof coating for silos, tanks & bunds
- Footbridges & stair treads
- Car parks
- Rail, air & marine ports
- Ramps & pedestrian footways
- Stadiums & warehouses
- Industrial storage yards

Structural Bearings



	Page
EKE - Elastomeric (EN1337-3:2005)	30
KE - Fixed & Sliding (EN1337-5)	31
DE - Line Rocker (EN1337-6)	32
GE - Spherical (EN1337-7)	33
FE - Restraint & Guide (EN1337-8)	34
EKR - Rubber Pad & Strip (EN1337-3:2005)	35

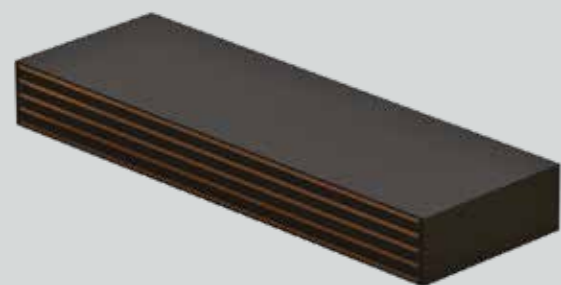

Fig. 1



Ekspan laminated elastomeric bearings are produced to the latest Eurocode EN1337-3:2005. Although standard sizes are shown within the literature bespoke bearings can be produced upon request.

Laminated elastomeric bearings consist of natural rubber layers separated by steel plates. Around this makeup a rubber cover encapsulates the bearing (Fig. 1). These items are then vulcanised to create a compact maintenance free bearing. Elastomeric bearings can absorb horizontal movements in every direction and rotational movements around every axis through elastic layers deformation. They are used for short to medium span structures. Once correctly installed these bearings require very little maintenance.

Natural rubber is not too sensitive to changes in temperature and shows only slight growth in deformation, over the period of deformation at a constant load (low creep). Natural rubber is highly resistant against ozone, ageing, UV and chemical effects. The vulcanized steel reinforcement plates meet the requirements of BS1449.

Advantages:

- Easy to install
- Maintenance free
- Continuous functionality for providing long service life
- Operate well at very high or very low temperatures

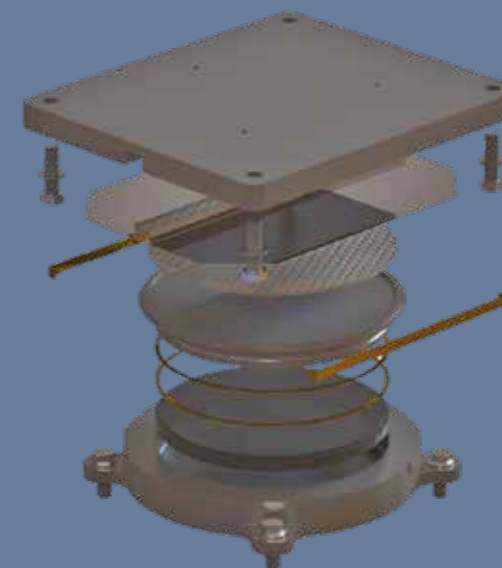

Ekspan KE range of pot bearings are designed to allow the correct transfer of load whilst allowing rotation about all axis. The bearings are also designed to either allow or restrain translations depending on your requirements. The rotation is accommodated by a moulded 60IRHD rubber pad contained within the pot, restrained by a pair or trio of brass piston rings.

Designed in accordance with EN1337-5

Load Capacities:

- Vertical load capacity up to 46,287kN ULS
- Horizontal load capacity up to 3,900kN ULS
- Rotational capacity up to 0.015 radians

Advantages:

- Fully welded sliding surfaces
- Fully certified EN compliant materials
- Integrated guides to allow for accurate positioning



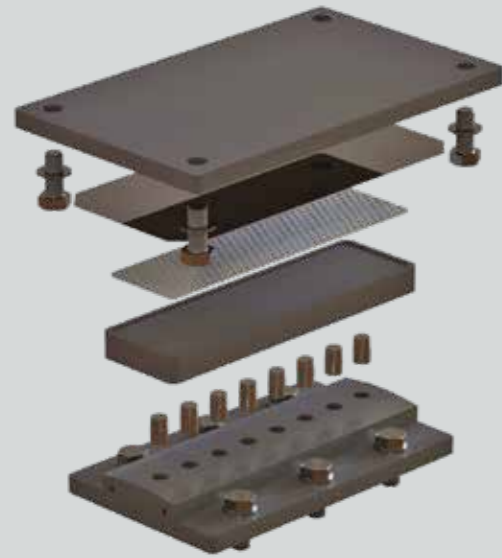

Ekspan DE range of rocker bearings are designed to allow the correct transfer of load whilst allowing rotation about a single axis. The bearings are also designed to either allow or restrain translations depending on your requirements. The standard load capacities are shown, however larger bearings can be manufactured upon request.

Designed in accordance with EN1337-6

Load Capacities:

- Vertical load capacity up to 6,000kN
- Horizontal load capacity up to 593kN
- Rotational capacity up to 0.02 Radians

Advantages:

- Fully welded sliding surfaces
- Fully certified EN compliant materials
- 0mm vertical deflection
- Ideal for long span rail structures

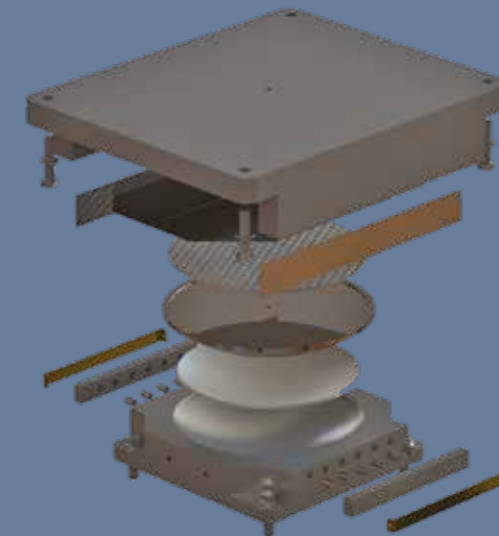

Ekspan GE range of spherical bearings are designed to allow the correct transfer of load whilst allowing rotation about all axis. The bearings are also designed to either allow or restrain translations depending on your requirements. The rotation is accommodated by a convex stainless steel piston mating against a PTFE sheet, which sits within the concave bearing base.

Designed in accordance with of EN1337-7

Load Capacities:

- Vertical load capacity up to 39,000kN ULS
- Horizontal load capacity up to 6,825kN ULS
- Rotational capacity up to 0.049 Radians

Advantages:

- Fully welded sliding surfaces
- Fully certified EN compliant materials
- Integrated guides to allow for accurate positioning
- Ideal for highly skewed structures
- Stainless steel spherical piston for added corrosion protection (dependant on size and material availability)



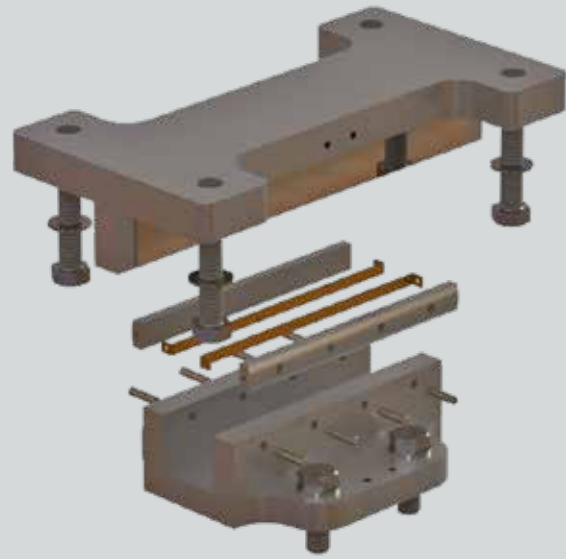

Ekspan FE range of restraint and guide bearings are designed to resist only horizontal forces induced into the structure. These bearings are commonly used in conjunction with laminated elastomeric bearings to resist the horizontal forces. The bearings can be designed to allow for rotation about all axis whilst having a capacity of +15mm – 10mm vertical translation, which is very useful for future bearing replacement. This allows the structure to remain restrained during jacking and replacement of the laminated elastomeric bearings, reducing the need for significant temporary works.

Designed in accordance with EN1337-8

Load Capacities:

- Vertical load capacity 0kN
- Horizontal load capacity up to 2,300kN
- Rotational capacity up to 0.01 Radians (21FE and 10FE)
- Rotational capacity up to 0.01 radians longitudinally and 0.04radians transversely (31FE)
- Vertical translation of +15mm – 10mm

Advantages:

- Fully welded sliding surfaces
- Fully certified EN compliant materials
- Vertical translation allows bearing replacement without the need for significant temporary works

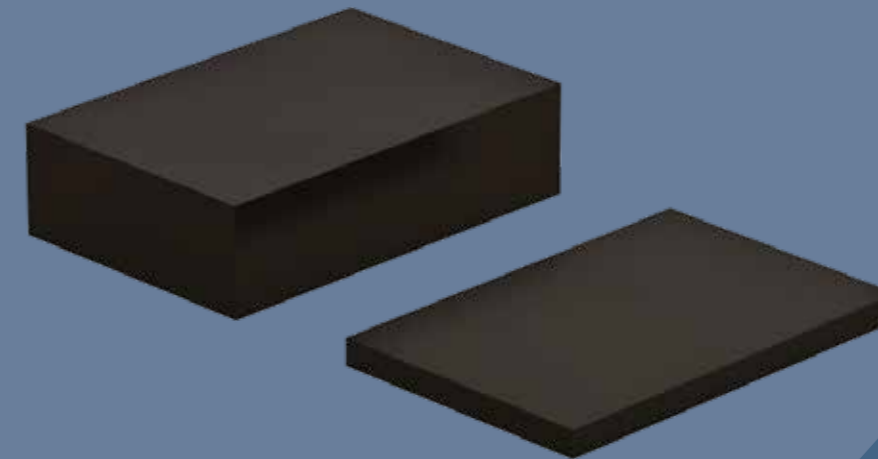

Natural Rubber strip can be utilised to support a concrete diaphragm and natural rubber pads are used to support individual beams. These products are commonly used where the vertical loads/translations are relatively low.

Where increased vertical load capacity/translations and rotations are required then the preferred option would be to utilise a laminated elastomeric bearing.



Injection Resins



Soil & Ground Stabilisation
Leak Sealing

Page
37
38



Sound concrete relies upon a solid substrate. Well-compacted soils provide a foundation upon which concrete structures perform. Decomposing soils, erosion and freeze-thaw cycles can destroy this foundation. That is the root cause for damage to or failure of structures such as buildings, highways and airports.

Major excavation is not required for stabilising soil. Injecting polyurethane chemical grouts into loose or less dense soils, voids, pores and fissures strengthens the earthen substrate and provides watertight encapsulation.

Nufins can provide soil stabilisation solutions with its Prime Flex polyurethane and acrylate foams and gels.

Prime Flex 910 & 920

Permeation grouting, void filling, curtain grouting, sealing high flow gushing leaks.

AR 800 & 870

Permeation grouting of sandy or silty soils. Long variable set time allows for thorough penetration.

There are many benefits of using chemical grouts vs substrate replacement or excavation repair:

- Less disruptive
- Faster
- Less expensive
- Less environmental impact
- Safer
- Permanent

Typical structures requiring soil stabilisation:

- Roads/highways
- Bridges
- Railway sleepers
- Airport runways, taxiways
- Tunnels
- Seawalls
- Storm water pipes
- Tanks
- Foundations
- Pools



All leaks are not the same. There are many types of leaks and Nufins offers different solutions to address each size and type. Whether your issue is hairline cracks or high flow gushing leaks, we've got a solution.

Factors to consider when choosing how to seal a leak include:

- Volume of leak
- Size of crack or defect
- Accessibility of the site
- Environmental conditions
- Expansion rate, set time and viscosity of the grout
- Physical properties of reacted grout: foam versus gel, rigid versus flexible

Prime Flex 900 MV & XLV

Injecting cracks, expansion joints, wide cracks, pipe joints or pipe penetrations. Sealing active leaks in above - or below-ground concrete structures.

Prime Flex Hydro Gel SX

Sealing underground structures; ideal for manholes

AR 800 & 870

Leak sealing and soil consolidation; ideal for geotechnical applications

Examples of typical structures requiring leak sealing include:

- Manholes
- Dams
- Tunnels
- Underground parking decks
- Storm sewers
- Water treatment tanks
- Pipe joints
- Elevator pits
- Retaining walls
- Box culverts
- Seawalls
- Potable water tanks
- Underground vaults, walls, pits and floors
- Nuclear plant cooling tanks

Concrete Repairs



Repair Mortars
Protective Coatings

Page

40

41



The performance of concrete as a construction material depends on a number of factors; its original quality, exposure conditions, design and the standard to which it has been applied, all have a bearing on its durability.

All concrete will be subject to chemical and physical change. However one of the main causes of concrete failure is due to reinforcement corrosion. The following CE labelled materials can be used for repairs to improve the alkalinity of the damaged areas.

Nucem Primer

A cementitious epoxy blend, with long tack free time, designed to promote extremely high bond strengths. Recognised as one of the best available, the epoxy primer system can be used in wet or dry conditions. In addition, Nucem Primer protects reinforcement against further corrosion even under the most adverse conditions.

Nucem HB Mortar/Acropak HB40 Mortar

Polymer modified, shrinkage compensated, fibre reinforced, cementitious mortars with high build characteristics for vertical and inverted surfaces without the need for shuttering. Polymers reduce damage from CO₂, ingress of water, chlorides and certain sulphates. Nylon fibres reduce shrinkage cracking, make the mortar easier to apply and greatly increases the flexural strength of the system. Complies with BD27/86 Clause 6.

Nucem Concrete/ Nucem Mortar

Prepacked polymer modified systems which contain specially graded aggregates for high strength and abrasion resistance on decks. Excellent resistance to water, frost and salt permeability enabling these products to be used for heavy duty repairs under the most adverse conditions.

Suitable for next day waterproofing. Complies with BD27/86 Clause 6.

Epibear

Epoxy bridge bearing mortar. Designed specifically for bridge bearing pad levelling plinths and other load bearing applications. Develops high strengths quickly even at low temperatures. Used in conjunction with Epicon Primer/Tack Coat 'H'.

Deck Repair Rapid

Deck Repair Rapid is characterised by its early high strength development, rapid moisture loss and shrinkage compensation. Designed for quick, easy installation and suitable for next day waterproofing of bridge decks and areas where rapid turnaround is important. Complies with BD27/86 Clause 6.



Nucem Skim Coat

A blend of high grade cements, fine aggregates and acrylic resin designed to produce a flexible levelling coat to cover areas repaired and existing concrete. Nucem Skim Coat gives an overall uniform appearance or a consistent surface to receive protective coatings. Polymer modified, capable of bridging hairline cracks and ideal for treating areas with low reinforcement cover. Tested by Taywood.

Proflex 'A'

Flexible, anti-carbonation coating. A high build acrylic emulsion designed to protect concrete from the ingress of rain water and air-borne pollutants, while allowing substrates to breathe. Also suitable for protection and decoration of a wide range of wall and sheet roofing materials. Tested by Taywood.

Covercrete

Highly durable weather-resistant anti-carbonation coating. This water-based acrylic emulsion is designed to significantly reduce the diffusion rate of Carbon Dioxide and protect from chloride attack. Available in a range of decorative colours. Tested by Taywood.

Nucryl

An effective clear anti-carbonation coating. Solvent borne Acrylic treatment with excellent resistance properties that provides a long-lasting barrier to protect against Carbon Dioxide, for the protection of substrates from aggressive atmospheric contaminants.



Kerb & Bridge Drainage



	Page
Envirokerb	43
Envirobridge	44
Envirodeck	45
Dri-deck	46
325 System	47

Since its introduction in 2002, **Envirokerb** has become recognised as the lightest, strongest and greenest kerb drainage solution on the market. Over half a million units of **Envirokerb** have been installed in hundreds of schemes spanning a growing number of countries from the UK to Germany, the Czech Republic, Ireland, Italy, Slovakia and more. **Envirokerb** is the ideal solution for kerb drainage on motorways, trunk roads, car parks and other urban areas.

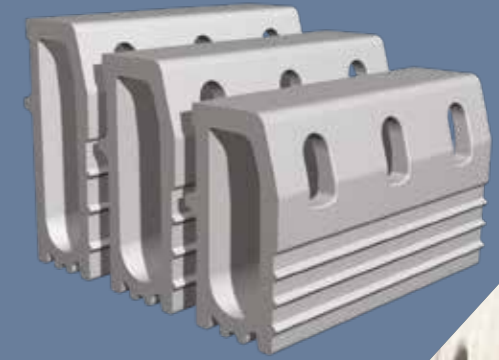

What our Customers say...

"Because it's a one part system rather than a two part system, and it's lightweight, the rate you can lay at is probably twice as much, if not more [than two-piece concrete products]." **Adam Fowell, Birse Civils, Darlington Eastern Transport Corridor**

"The product has proven to be very strong, and we have experienced no breakages. Once in-situ the product has the appearance of concrete and blends exactly with existing kerb-lines. We would have no hesitation in recommending the product" **Nottinghamshire County Council**

"The **Envirokerb** offers the perfect solution. At 15kg it is lightweight enough for manual installation. We have not had a single breakage or chipping to kerbs and the product has proven to be stronger in all aspects than the traditional concrete kerbs" **Birmingham City Council Highways Dept**

"We find using **Envirokerb** gives us up to 400% more production per day over conventional two-piece units" **Jonny Edwards and Son, Kerb-laying contractors**

Features and Benefits

Envirokerb combines innovation in design with unique materials to create a product that is strong, lightweight and durable. Read more about how our products can help you to meet the demands of health and safety, project efficiency and component quality.

Green Benefits

PDS take our environmental responsibility very seriously and recognise this is also important to our customers. Unlike traditional systems - which rely heavily on natural resources - **Envirokerb** drainage is made entirely from recycled materials that would otherwise be destined for landfill within the UK and overseas.

Read more about how the green benefits of **Envirokerb** continue through manufacture, installation and usage.

Quality Assurance

PDS have worked hard to ensure all of our products meet - or exceed - all the legal and regulatory requirements under both UK and European law. Both the **Envirokerb** range and PDS as a company are certified under the internationally recognized Quality Management Standard ISO14001 allowing our products to carry the CE mark of conformity.

Complete Product Range

Envirokerb is available in a variety of widths and depths in both half-battered or 45 degree splayed styles, with a wide range of components including gully chambers, rodding access units and numerous outlet possibilities.

Envirokerb is also available in a more compact version, **Envirokerb Shallow**. The shallower depth makes it ideal for linear drainage in projects where construction depths are limited. It can provide continuity with **Envirokerb** drainage systems from carriageways over structures. It can also be used for roads and bridges where low flows are anticipated.

For the full range please view the **Envirokerb** brochure or contact us to discuss your requirements.

"The **Envirokerb** offers the perfect solution. At 15kg it is lightweight enough for manual installation. We have not had a single breakage or chipping to kerbs and the product has proven to be stronger in all aspects than the traditional concrete kerbs" **Birmingham City Council Highways Dept**



What our Customers say...

"The advantages with **Envirodeck** is that it is a single colour product of high durability, eliminating the need for any maintenance. Each individual unit can be handled by one man, and it's fully compliant with the manual handling regulations. Any other product would require a two-man lift or mechanical plant to help lift it into place"

Due to the huge success of the Envirokerb Road Drainage product, PDS have developed the **NEW EnviroBridge** System for Structures and restricted depth construction.

- Three additions to Envirokerb Range.
- Manufactured as a high strength one-piece monolithic unit.
- Ideal for areas where construction depths are limited i.e concrete slabs, Bridges, roads built as a slab or structure, underpasses and above culverts.
- 3 widths dependant on Hydraulic run-off.
- Allows continuity of Envirokerb drainage from carriageways to structures.
- Sub-surface drainage facility to help drain asphalt matrix.
- Fully compliant to EN1433 D400KN for Kerb Drainage Systems.
- Lightweight for installation advantages (19kg for heaviest product).
- Non-Metallic and therefore non-oxidising.

The product is available as 150mm, 220mm and 310mm wide with various depths depending on the Kerb Profile required (75mm, 100mm or 125mm splay or HB).

PDS PLC are the World leaders in Bridge Drainage, supplying over 90% of Structures in the UK and Ireland. Our reputation for quality of product and service has led to orders in Spain, Switzerland, Italy, Abu Dhabi, Singapore, Germany and recently the Czech Republic.

It was always our ambition to increase our range of lightweight, Environmentally friendly products and as our International business grows this becomes much more important.

The product has all the advantages of the existing Envirokerb range, including superb impact resistance, Lightweight for manual handling, aesthetics very similar to concrete and of course the benefit of a product manufactured in 100% Recycled material.

For the full range please view the Envirobridge brochure or contact us to discuss your requirements.

Envirodeck is the number one selling bridge drainage system for the UK and Ireland.

A combination of innovative design and a composite non-metallic material gives a one-piece unit that is lighter and stronger than traditional systems.

Envirodeck provides both surface drainage and sub-surface drainage. As advised by Highways England this is recommended to prevent serious damage to the waterproof membrane and pavement, and helps you to avoid costly and disruptive repairs.

Features and Benefits

Envirodeck shares the benefits common to the other products in our Enviro-range in terms of strength, durability, appearance, and finish. In addition the following benefits are specific to bridge drainage.

Reduced Bridge Load

Envirodeck is made from a composite material that reduces unit weight by over 50% compared to metallic units. This reduces the load on new and refurbished bridge structures and the amount of traffic needed to transport units to site.

Anti-slip Surface

Envirodeck has a unique anti-slip pattern that is impossible to achieve with metallic units and is ideal for bridges with pedestrian access.

Superior Appearance

Envirodeck is made from a composite material that does not rust. The units can be supplied in a range of colours to complement the bridge design or to delineate road edges.

Quality Assurance

PDS have worked hard to ensure all of our products meet - or exceed - all the legal and regulatory requirements under both UK and European law. Both the Envirokerb range and PDS as a company are certified under the internationally recognised Quality Management Standard ISO14001 allowing our products to carry the CE mark of conformity.

Complete Product Range

Envirodeck is available in a wide range of widths and depths, as well as half-battered or 45 degree splayed styles, to meet project requirements.

For the full range please view the **Envirodeck** brochure or contact us to discuss your requirements.

While **Envirodeck** provides both surface and sub-surface drainage you may also want to consider installing our Dri-deck system to ensure the bridge deck remains completely free from sub-surface water.



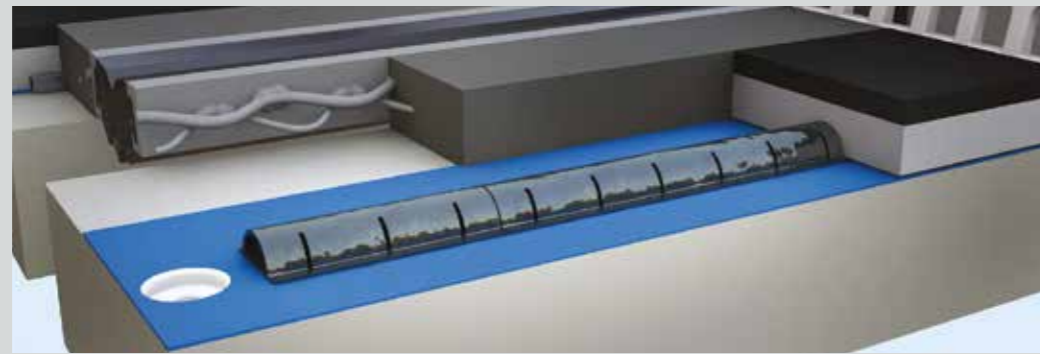
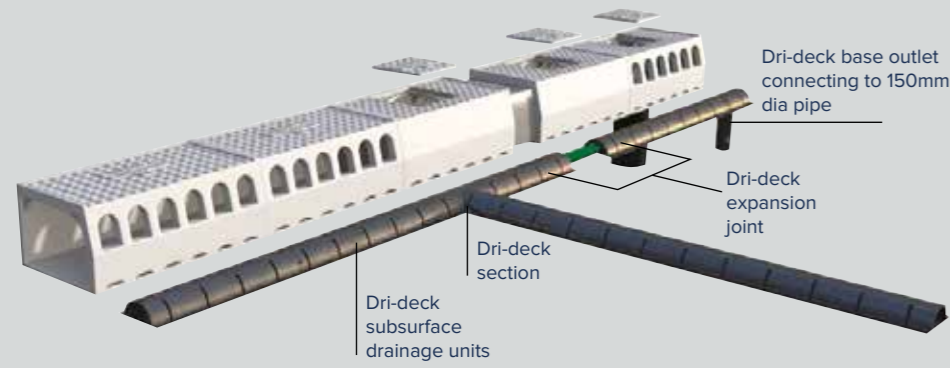

Dri-deck is a complete solution for the collection of water at the sub-surface level that can be used in conjunction with our Envirodeck & EnviroBridge combined kerb drainage systems.

Why use Dri-Deck?

Highways England has highlighted the need for effective sub-surface drainage to prevent serious damage to the waterproof membrane and pavement. Such damage can require costly and disruptive repairs.

Combined kerb drainage systems can be effective in draining sub-surface water. However the base thickness of the unit, the mortar bed, and any regulating course can raise the sub-surface collection holes above the deck level. **Dri-deck** provides the ideal system to capture any remaining water at this level.

High Strength Ductile Iron Channel

Dri-deck channel units come in slotted one-metre sections manufactured in graphite iron. The **Dri-deck** channel provides continuous sub-surface water collection with a range of T-pieces, bends and cross sections allowing a number of drainage designs.

ABS Heat Resistant Outlet Fittings

The outlet units for **Dri-deck** are comprised of a recessed base unit which fits smoothly with the waterproof membrane, and cover made from high strength thermoplastic material that is heat resistant and highly durable under pressure. Inlet holes at the top and bottom of the cover unit allow drainage from above and below the waterproof membrane.

Wide Range of Beneath Deck Pipes

A compatible system of pipework is available including a full range of pipe hangers, supports, and fittings to allow carrier pipes to cross expansion points.

Health & Safety

Dri-deck unit weights are up to 50% lighter than other products on the market and fall within the new manual handling guidelines, avoiding workplace injuries and saving dead weight on both new and refurbishment structures.

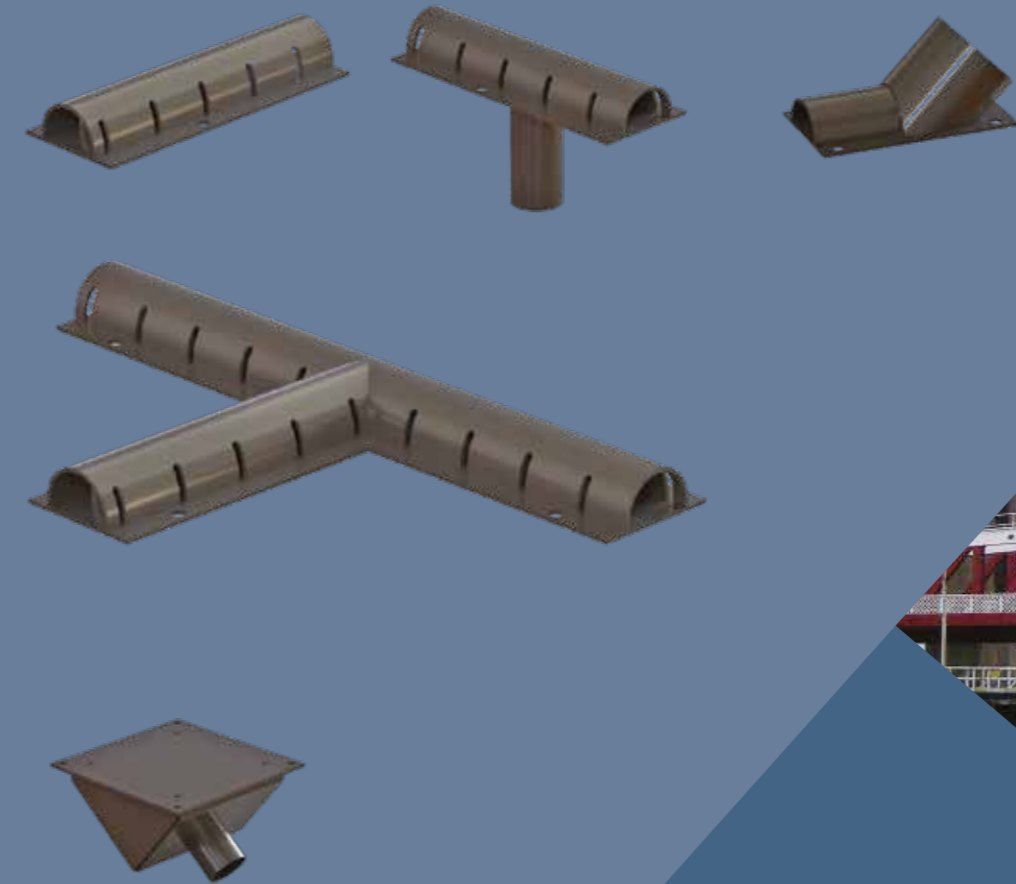

Ekspan 325 is a long lasting galvanised steel fabricated section designed to remove surface water seepage from the waterproof membrane level of bridge decks, most especially at low points adjacent to expansion joints and kerb lines. This system is unique in that it utilises the flushing box which allows cleaning and maintenance vital to system integrity and life time operation.

It is designed in accordance with Highways England BA26/94 and fully compatible with the Ekspan 302 Through Deck System.

The system is Blacktop Heat Proof and polyester resin mortar is used to prevent voids under the channel during installation.

Drain Section

Each section of drainage channel is 2m long. End stoppers can be used at all open ends to prevent ingress of blacktop.

Outlets

Designed to suit Ekspan 302 through deck tube. Available as straight or 90 degree cranked. 4-way junctions and T- Pieces.

Joints

Inter-connect drain section on the deck surface. Available as T, cranked joints left hand and right hand Y pieces.

Transition Piece

Enables convenient access to the **325 system** for periodic cleaning.

Flushing Unit Verge Box

Allowing access to system with water jetting equipment for cleaning, removing any silt and evaporative deposits. The flushing verge box is not designed to take any wheel loading therefore must not be installed on the carriageway.

Special arrangements can be made to order if required, for example joints to suit skew angled decks.



Project: RA167 Jamal Al Naser Street – Construction, Completion and Maintenance of Roads, Overpasses, Storm Water Drainage, Sewer and Other Services
Client: Ministry of Public Work - Kuwait
Main Contractor: ROBT JV

Project in brief: 420,000m² of PmB Bridge Deck Waterproofing was applied to 15km of Elevated Segmental Viaducts and Ramps.



Project: Bosphorus 1 Bridge, Turkey
Product: Britdex MDP
Main Contractor: EPO

Project in brief: Britdex MDP waterproofing applied to steel bridge deck of this world famous structure.



Project: Metro Manila Skyway, Philippines
Product: Britflex BEJ
Client: Philippines Highways Department
Main Contractor: Citra Marga

Project in brief: Installation of 414 metres of Britflex BEJ.



Project: Rontal Bridge, Lucerne, Switzerland
Product: Kerb and drainage units
Client: Basler & Hofmann

Project in brief: 1500 linear metres of Envirodeck units were supplied to this major project in Switzerland.



Project: Second Severn River Crossing, UK
Product: PmB
Client: Second River Crossing PLC

Summary: The bridge connects England to Wales. The overall length of the crossing structure is 5,128m. The bridge decks comprised of precast concrete segments.

PmB waterproofing system was selected after a six month study including site trials and in-situ testing.

The waterproofing was applied to the entire structure which included Shoots bridge, Welsh approach and English approach viaducts.

The total area for waterproofing was 176,000m².

PITCHMASTIC PmB

International

International Office

Al Barsha 1, B8 Building
Office 204, Dubai, UAE

t: +971 (0)4 234 9752

e: info@pitchmasticpmb.co.uk

Asia Pacific Office

39 Ubi Road 1#01-00
World Publications Building
Singapore

t: +65 (0)6848 7160

f: +65 (0)5749 0038

European Office

Panama House
184 Attercliffe Road
Sheffield
S4 7WZ
UK

t: +44 (0)114 270 0100

www.pitchmasticpmb.com