

MGB 1100L GALVANIZED STEEL BIN

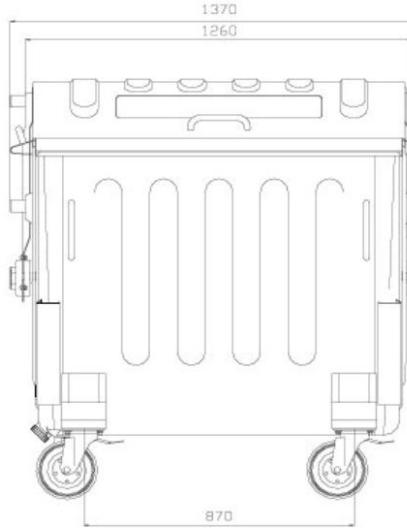
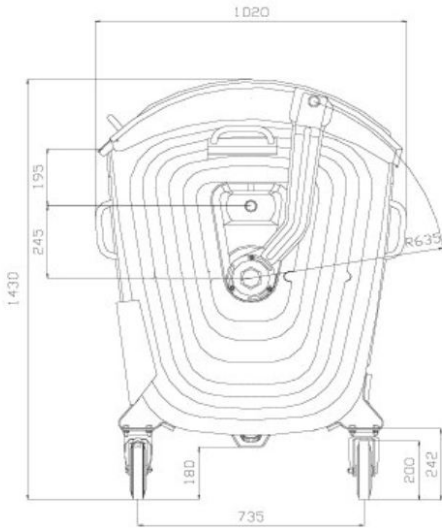

TECHNICAL DATA

CAPACITY	1100 L
WEIGHT	120 Kg (approx.)
DESCRIPTION	Hot dip galvanized steel, 1.25mm thickness, corrosion resistant wheels Ø 200mm, 360° swivel with 2 wheel stopper. The container is equipped with re-closing springs fitted to each lid guide arm to make the lid easy to close again. A rubber hand guard rim at the lid ensures safe filling, but also provides optimum seal against odours when closed and reduces the noise of closing. The conical shape of the base and the drain plug make the bin easy to clean.
OPTIONAL	Glass / paper opening, Child security device, Towing system, Central wheel breaking system, Triangular lock, Fork lift pockets, Comb with 2 wheel handles.