

# WAFER ÇALPARA ÇEK VALF (PN 16)

## -WAFER SWING CHECK VALVE (PN 16)

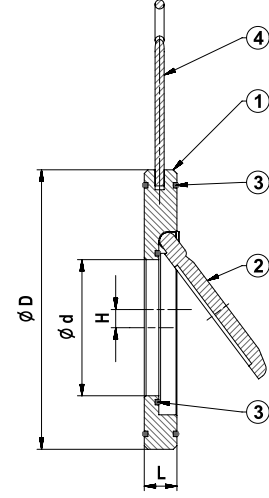

T-0430 Karbon Çelik Döküm / Cast Carbon Steel

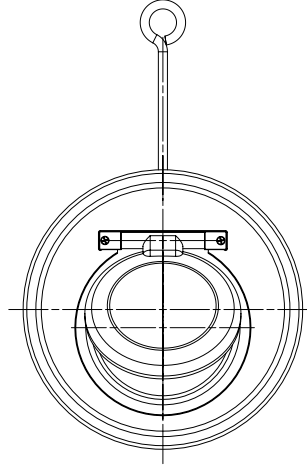

### Genel Özellikler / General Specifications

Çalışma Sıcaklık Aralığı / Working Temperature : -10 ... +120 °C (16 Bar)

### Standartlar / Standards

Sertifikalar / Certificates : CE

Flanş Boyutları / Flange Dimensions : TS EN 1092-2 (PN 16)

Testler / Tests : TS EN 12266-1

### Uygulamalar / Applications

Deniz suyu (paslanmaz çelik), kondens sistemleri (paslanmaz çelik), arıtma sistemleri, HVAC sistemleri  
Sea water (stainless steel), condensation systems (stainless steel), purification systems, HVAC systems

Malzeme Özellikleri / Material Specifications	No	Parça Adı / Part Name	Malzeme / Material
			1
2	Klape / Disc	GS-C 25 - GP240GH Karbon Çelik Döküm + Nikel Kaplama / Cast Carbon Steel + Nickel Plated (T-0430) - Cast Stainless Steel (T-0450)	
3	O-Ring / O-Ring	EPDM - NBR	
4	Mapa / Eye Bolt	St 37 - Çelik + Nikel Kaplama / Steel + Nickel Plated	

Ölçüler / Dimensions	16 Bar															
	Anma Basıncı / Nominal Pressure															
Anma Çapı / Nominal Diameter	DN	40	50	65	80	100	125	150	200	250	300	350	400	500	600	
Vana Boyutları / Valve Dimensions	ØD	92	107	127	142	162	192	218	273	329	384	444	491	610	724	
	Ød	22	32	40	54	70	92	114	154	200	235	280	316	405	486	
	L	14			18			20	22	26	28	38	44	56	62	
	H	0		2	3	4	5	6	8	9	10	11	12	13	15	
Ağırlık / Weight	Kg	0,7	0,8	1,2	1,5	2,3	3,5	4,1	7	12	18	22	25	30	40	